

Model:

T120U

Erba Kälte
GmbH

DATA

General Data

Type	Hermetic Reciprocating
Technology Type	On-Off
Displacement	12,00 cm ³
Compressor Cooling	Fan
Expansion Device	Capillary Tube or Expansion Valve
Approval	CE
Power Supply	220-240 V / 50-60 Hz
Evaporating Temperature Range	-40 °C to 0 °C
Refrigerant	R 290

Electrical Data

Motor type	CSIR
Starting Torque	HST
Start Winding Resistance	25 °C: 21.0 Ω ± 10 %
Run Winding Resistance	25 °C: 6.0 Ω ± 10 %
Locked Rotor Current (LRC)	15,0 A

Mechanical Data

Oil Charge	200 ml
Oil Type Configuration	ESTER
Oil Type Viscosity	ISO32
Weight	10,2 Kg

Electrical Components

	Description
Motor Protection	GQR12U
Starting Device	GQR12U
Start Capacitor	50 μ F

External Characteristics

Tray Holder	No
Connector	Internal Diameter
Suction	6,2 mm \pm 0,1
Discharge	6,2 mm \pm 0,1
Process	6,2 mm \pm 0,1

PERFORMANCE

Performance Curve Data ASHRAE

Cooling Capacity ASHRAE +55°C												
-40°C	-35°C	-30°C	-25°C	Test Conditions: -23,3°C				-20°C	-15°C	-10°C	-5°C	0°C
W	W	W	W	Capacity (W)	Input Power (W)	Current (A)	COP (W/W)	W	W	W	W	W
275	325	405	475	550	399	2,6	1,45	605	688	805	942	1102

Operating Envelope

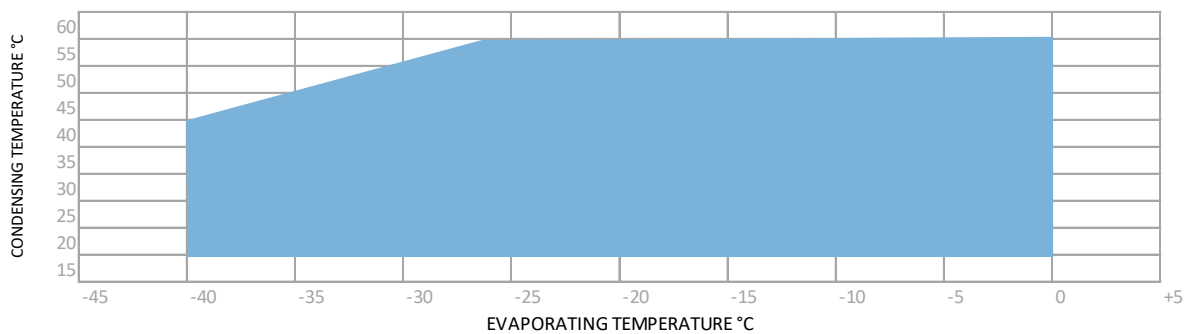

External Dimensions

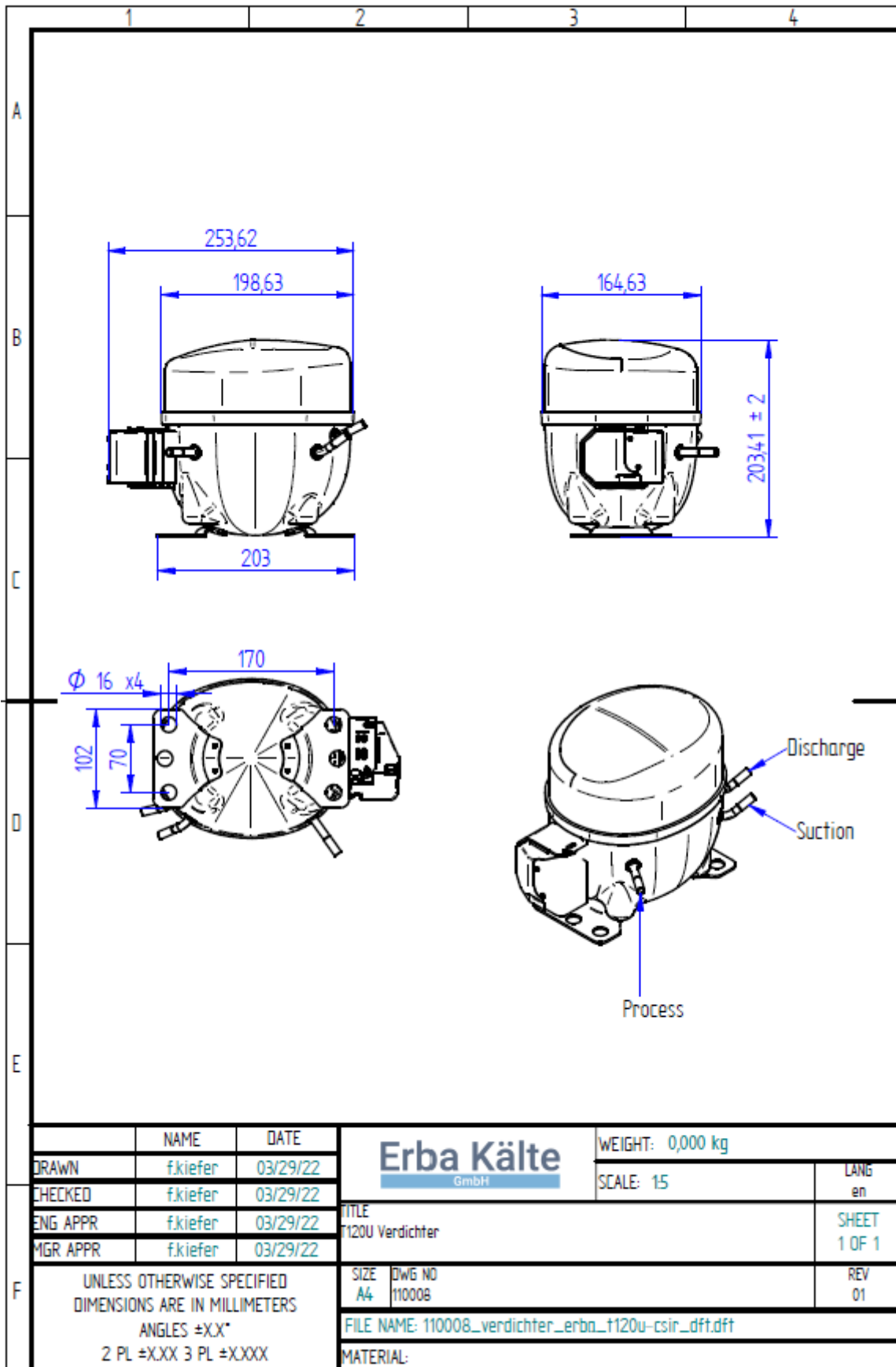

Electrical Connection Picture

